

2025 Product Catalog



DRYERS



SIGNAGE

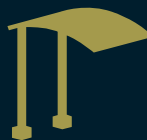

STRUCTURES



VACUUMS



PALM DRYERS



LED LIGHTING

premier

Your Manufacturing Partner

premier

Dryers



- Arch Dryers 4
- Exterior Wall Mount Dryers..... 6
- Interior Wall Mount Dryers..... 7
- Tunnel Dryers 8
- Producers..... 9
- Custom Large Vehicle Dryers..... 11
- Evolution Series..... 12
- Air Blanket for Evolution Series 14
- UL® Listed VFD & Starter Panels 15

Signage



- Arches & Overheads 16
- Menu & Menu Boards 21
- Pedestals & Wall Mounts 22
- Roto-Molded Signs 22
- Tunnel/Wall Signs..... 23
- Channel Letters 23
- Custom Shaped Wall Pedestals & Wall 24
- Printed ACM..... 25
- ACM In-Bay Signage 25
- WindMaster® Inserts & Pump Toppers..... 25

Who We Are

We are a family owned, industry-leading company, offering complete metal fabrication, finishing services and products. Premier Companies has its own product line that supplies the car wash, and many other industries with Dryers, Vacuums, Signage, LED Lighting and Canopy Stations. All of our products are proudly designed and manufactured in Central Wisconsin.

What We Do

The selection of products manufactured by Premier Companies are not only of the highest quality, but are also available in a variety of options to ensure you find exactly what you're looking for. With top-of-the-line materials, cutting-edge production technologies and a highly qualified team, we guarantee complete satisfaction.

PROUDLY MADE IN WISCONSIN, USA



Structures

- Pay Station Canopies 26
- Clearance Structures 27



Vacuums

- Stainless Steel Canopy Vacs 28
- Silver Bullet 30
- Stainless Steel Vacs..... 31



Palm Dryers

- Palm Dryers..... 32



LED Lighting

- Color Changing
LED Tube Lighting 34



Premier manufactures custom drying equipment for many industries all over the world. Many hours and years of experience studying air flow and air distribution have made our dryers number one on the market.

At Premier, our customers are our partners. We provide our customers with individualized solutions to maximize functionality for the perfect dryer system set up. Not only does Premier provide great products and service, we also lead in price, custom design, private labeling and dryer performance. Our positive and knowledgeable staff are ready and available to make your venture a profitable and enjoyable experience.

Floor Mounted Arch Dryers

MOTORS AVAILABLE IN 5HP, 7.5HP, 10HP OR 15HP

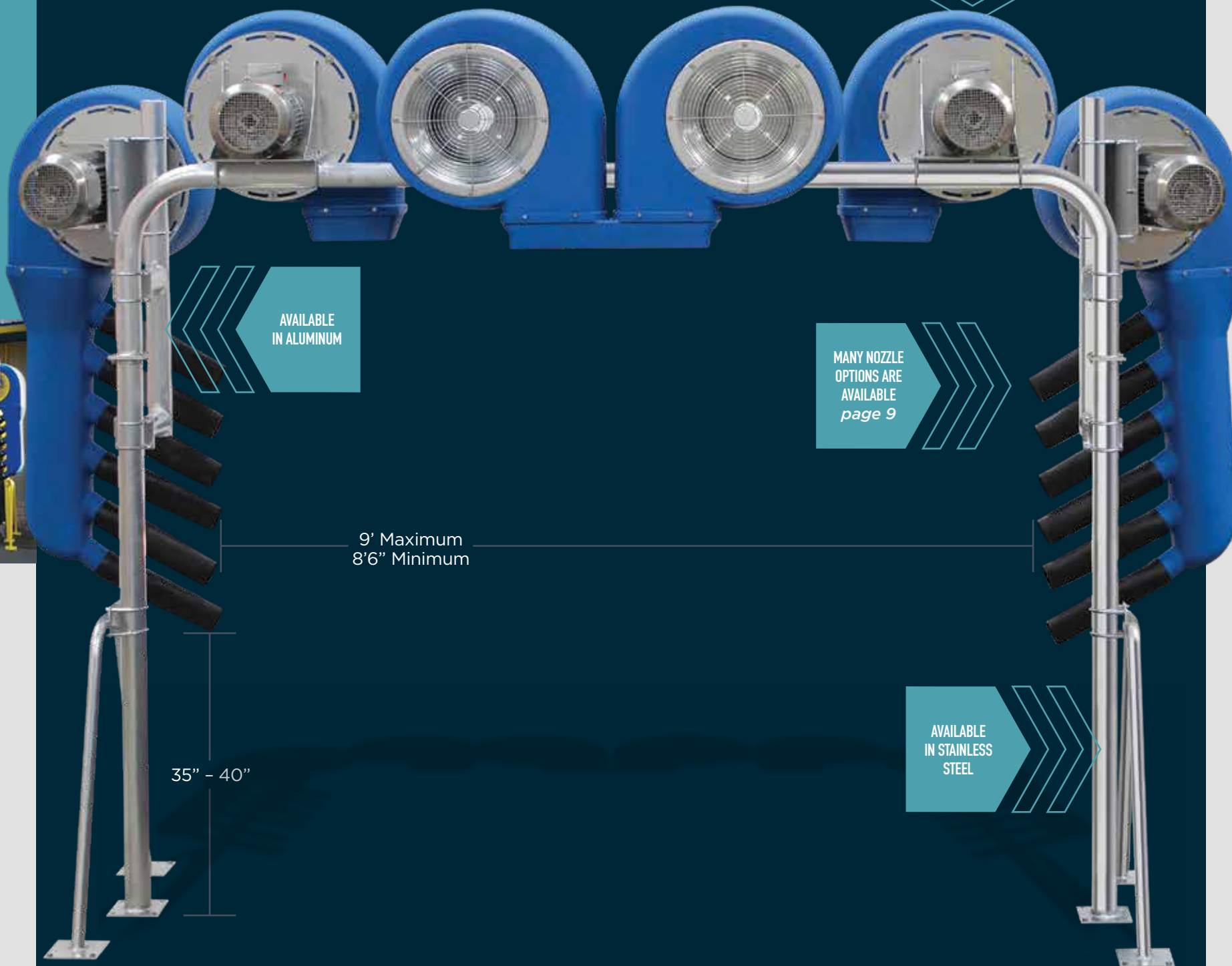

AVAILABLE IN ALUMINUM

MANY NOZZLE OPTIONS ARE AVAILABLE page 9

AVAILABLE IN STAINLESS STEEL

9' Maximum
8'6" Minimum

35" - 40"



- Arches available in aluminum or stainless steel:

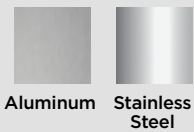

Aluminum Stainless Steel

- Standard dryer clearance is 90", but is fully customizable to any specs desired
- HDPE producer housing colors available:



Blue Black Granite Gray Red Green Yellow

Common Arch Configurations

Additional and customizable configurations are available. Please contact us.

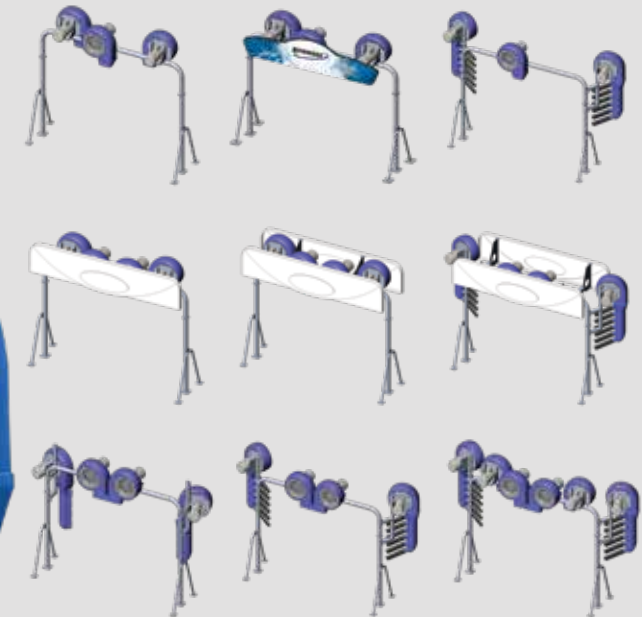

Arch Dimensions

Standard dryer clearance is 90", but is fully customizable to any specs desired.

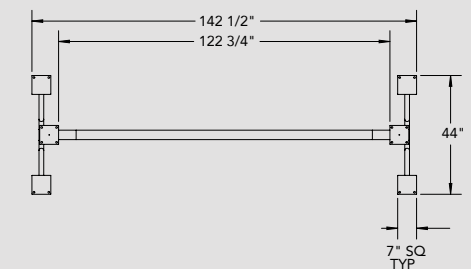
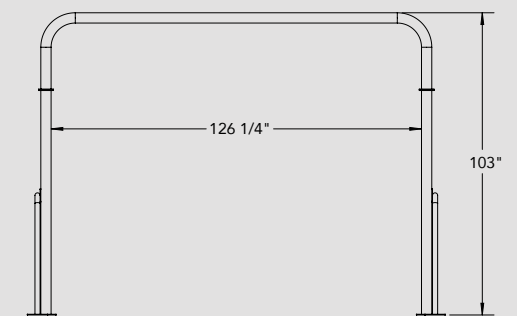



SEVERAL PRODUCER HOUSING COLORS ARE AVAILABLE

Exterior Wall Mount Dryers

VARIOUS POWDER COAT COLORS ARE AVAILABLE

Interior Wall Mount Dryers



- Aluminum and stainless steel available

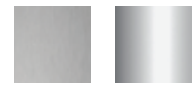

Aluminum Stainless Steel

- HDPE producer housing colors available:



Blue Black Granite Gray Red Green Yellow

- Standard powder coat colors are:



Blue Black Gray Red Green Yellow White

- Custom powder coat colors available by request

Common Exterior Dryer Configurations

Additional and customizable configurations are available. Please contact us.

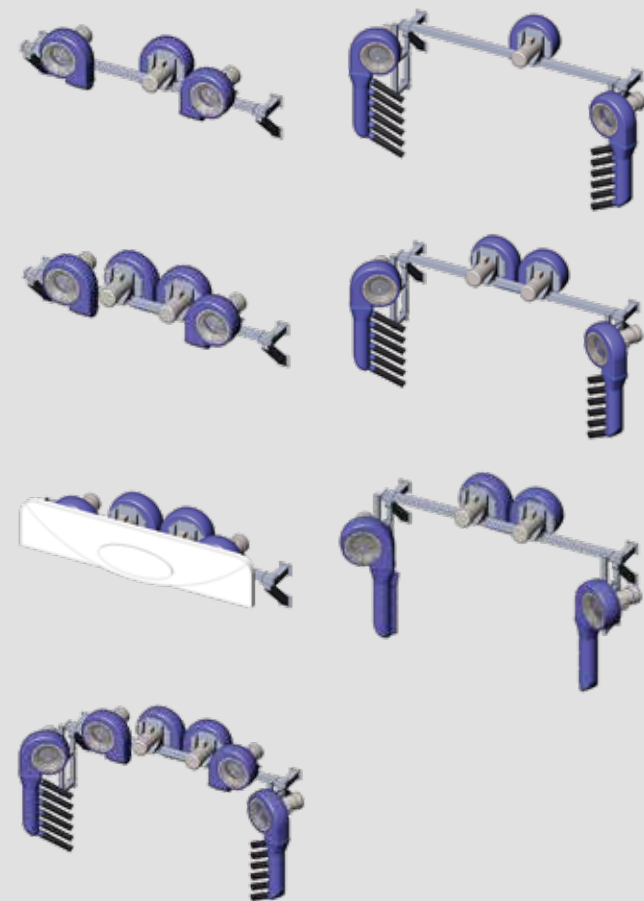

Common Interior Dryer Configurations

Additional and customizable configurations are available. Please contact us.

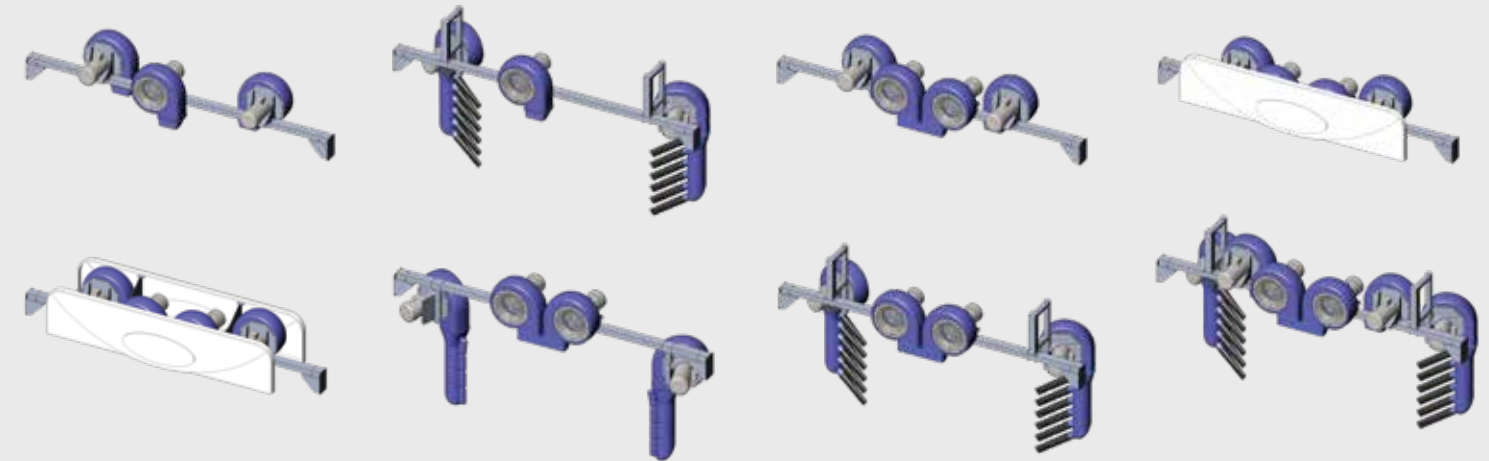



MOTORS AVAILABLE IN 5HP, 7.5HP, 10HP OR 15HP

Tunnel Dryer Applications

Common Tunnel Configurations

Additional and customizable configurations are available. Please contact us.

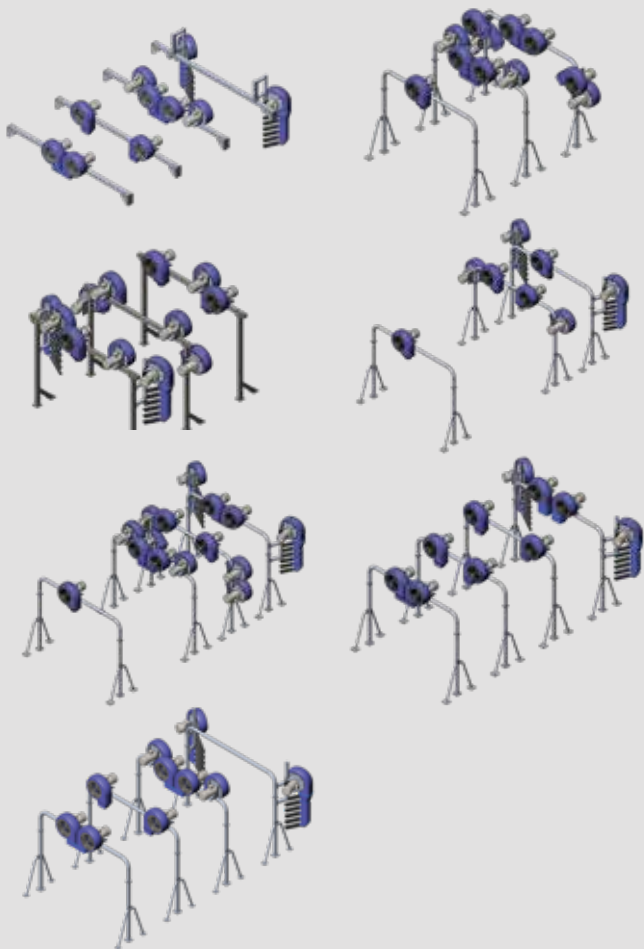

Producers

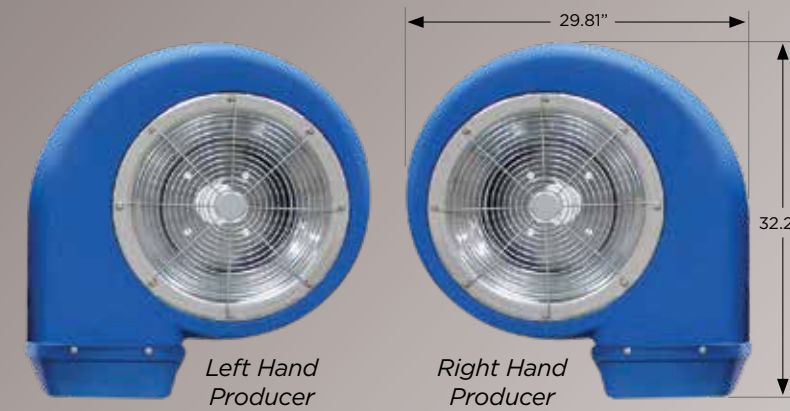

- HDPE producer housing colors available:



- Fiberglass cover with custom graphics available
- LED backlit cover with custom graphics available
- UL Listed VFD and standard starter panels available
- LED lighting available
- Custom applications available
- 5 HP available upon request

Producer Specifications

	7.5 HP Producer	10 HP Producer	15 HP Producer
208 V FLA	22.3 amps	29.0 amps	40.2 amps
230 V FLA	20.2 amps	26.2 amps	36.36 amps
460 V FLA	9.7 amps	13.1 amps	18.18 amps
SF amps	1.15 60 Hz / 1.0 50Hz	1.15 60 Hz / 1.0 50Hz	1.15 60 Hz / 1.0 50Hz
CFMs	3525	4200	4500
RPM	3540	3600	3600
Air Velocity	120 mph	135 mph	142 mph
TEFC Motors	3 Phase	3 Phase	3 Phase
Frame Size	213 Tc	213 Tc	213 / 5 Tc
Total Weight	119 lbs	119 lbs	128 lbs

Efficiency Level - (Minimum), 88.5% guaranteed efficiency, Nema NCM efficiency (Normal) 90.2%

Producer Nozzle Options



How Loud Are Our Producers?

Inside Door Closed

Distance From Bay	90 HP (6 - 15 HP)	60 HP (4 - 15 HP)	45 HP (3 - 15 HP)	10 HP (1 - 10 HP)
10 ft	102 dB	101 dB	100 dB	94 dB
20 ft	100 dB	99 dB	98 dB	92 dB
30 ft	98 dB	98 dB	98 dB	91 dB

Outside Door Open

Distance From Bay	90 HP (6 - 15 HP)	60 HP (4 - 15 HP)	45 HP (3 - 15 HP)	10 HP (1 - 10 HP)
10 ft	98 dB	95 dB	96 dB	90 dB
20 ft	92 dB	90 dB	89 dB	84 dB
30 ft	88 dB	86 dB	85 dB	79 dB
40 ft	84 dB	82 dB	82 dB	76 dB
50 ft	80 dB	80 dB	79 dB	74 dB

Decibel levels may drop 4 to 5 dB's or more with full cover surrounds or silencer cones. Readings may vary. Readings were conducted with Premier Plastic Housings.

Decibel Scale

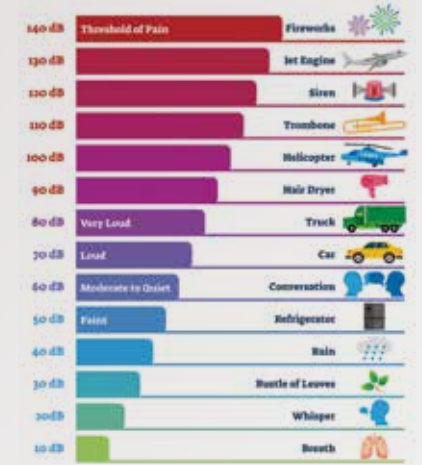

DESIGNED AND BUILT TO SUIT YOUR CUSTOMER'S NEEDS

Custom Large Vehicle Dryers



Common Large Vehicle Dryer Configurations

Additional custom configurations are available. Please contact us.

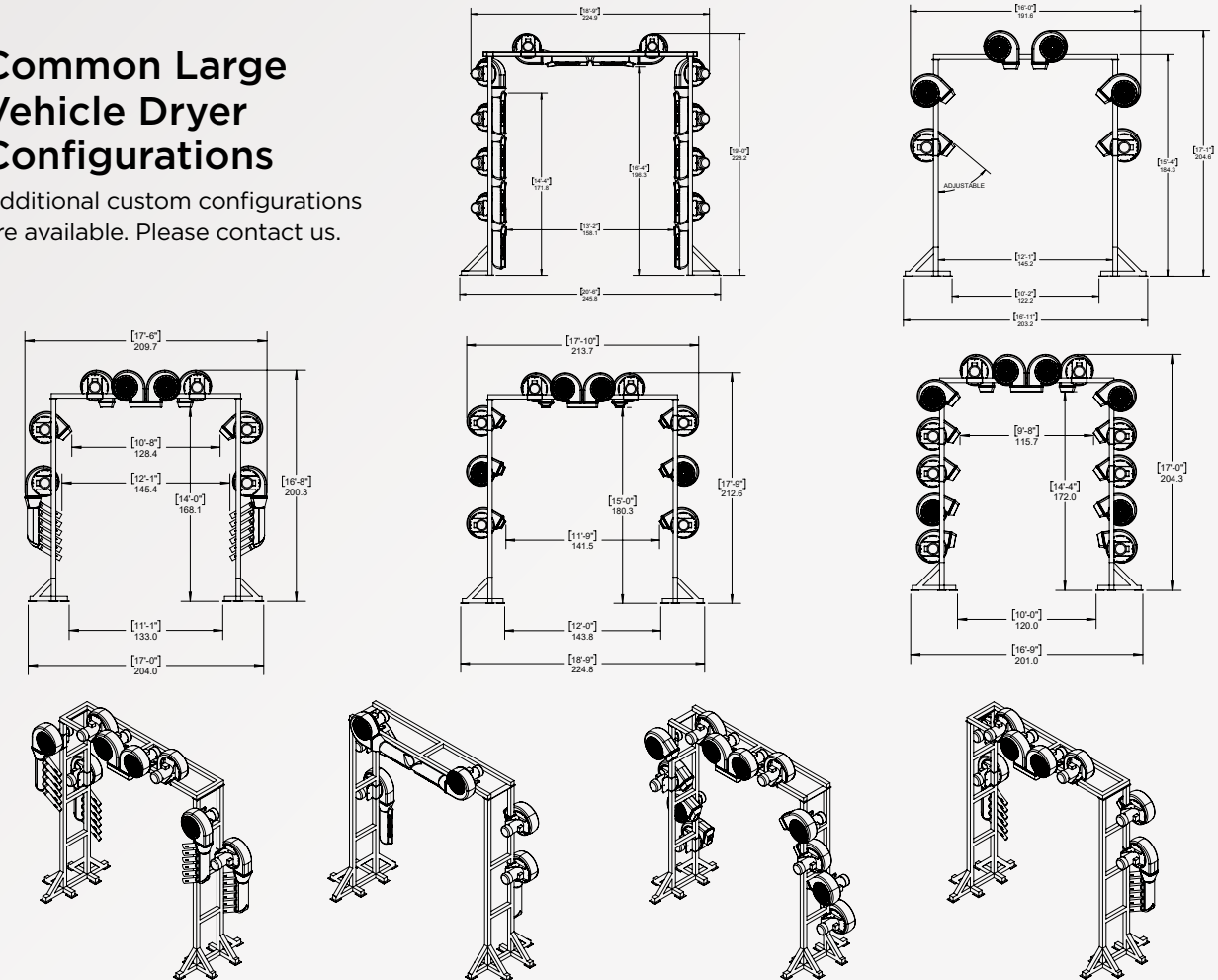



Introducing the New Evolution Series

Oscillating Nozzle | Flip Nozzle

Oscillating Nozzle

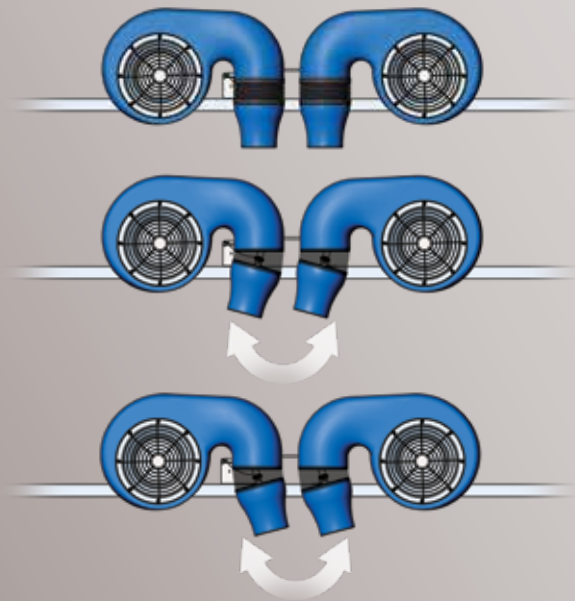

Oscillating Nozzle

- Swings left and right approximately 30 degrees
- Pneumatic or electric actuation
- Available in single or dual configurations



- HDPE producer housing colors available:

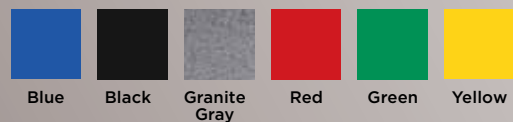

- Fiberglass cover with custom graphics available
- LED backlit cover with custom graphics available
- UL Listed VFD and standard starter panels available
- LED lighting available
- Custom applications available
- 5 HP available upon request

Flip Nozzle

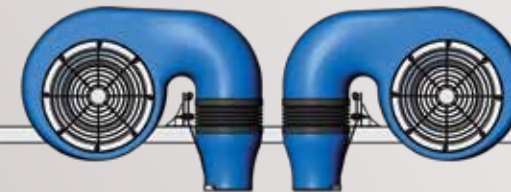

Flip Nozzle

- Swings approximately 15 degrees in both forward and backward directions
- Pneumatic actuation
- Activated by photo or sonar detection
- Available in left, right, or dual configurations

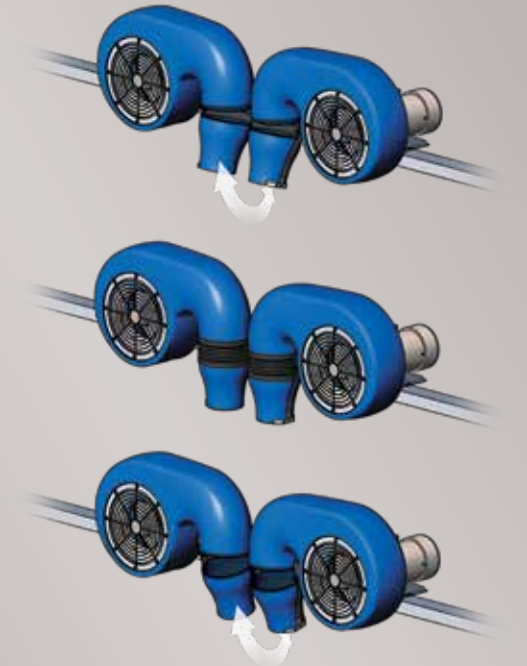

Fixed Nozzle Adapter

- May be used as a standalone nozzle, or as an adapter for air knives and e-trunks
- Allows an e-trunk or air knife to be adjusted 360 degrees



Evolution Producer Specifications

	10 HP Producer	15 HP Producer
208 V FLA	29.0 amps	40.2 amps
230 V FLA	26.2 amps	36.36 amps
460 V FLA	13.1 amps	18.18 amps
SF amps	1.15 60 Hz / 1.0 50Hz	1.15 60 Hz / 1.0 50Hz
CFMs	4500	4800
RPM	3600	3600
Air Velocity	140 mph	147 mph
TEFC Motors	3 Phase	3 Phase
Frame Size	213 Tc	213 / 5 Tc
Total Weight	119 lbs	128 lbs

Efficiency Level - (Minimum), 88.5% guaranteed efficiency, Nema NCM efficiency (Normal) 90.2%

Nozzle Extensions

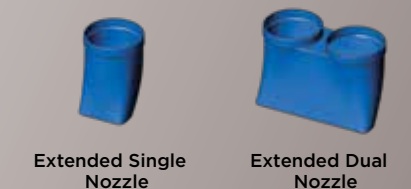

Air Blanket

For Evolution Series



The Air Blanket attachment for Evolution Series provides a narrow, high-velocity blade of air up to 8+ feet wide. This narrow air path is angled, to better push water off vehicles.

PROVIDES A NARROW, HIGH-VELOCITY BLADE OF AIR!

• HDPE producer housing colors available:



UL LISTED VFD and Starter Panels

SAVE ENERGY AND MONEY WITH OUR VFD PANELS!



Features and Benefits

- Yaskawa VFDs (world leading VFD manufacturer)
- Arrives pre-programmed to your specific needs
- User-friendly with 24/7 technical support
- Energy rebates may be available in your area
- Energy savings from avoiding start up current
- Eco friendly
- No mechanical moving parts
- Unlimited performance options
- Extends parts and motor life
- Replaces existing starter panel
- Reduces noise levels
- Great return on investment
- Saves you money

Save Energy and Money

- At **58 hz**, owner saves **19%** on energy cost.*
- At **57 hz**, owner saves **24%** on energy cost.*
- At **55 hz**, owner saves **32%** on energy cost.*

* Data collected from 10 HP 208 volt during 60 second dryer time.



Watch our video to learn more about Premier VFD panels.





Arches and Overheads

These days, a car wash is about more than just a clean car. It's about providing your customers with a unique experience that makes a big impact. Our line of LED arches and overheads are sure to do just that. All of our signs are 120 volt, and are fully customizable with pucks, dots or spinners.

Our team of graphic designers are ready to create a standout arch that elevates our customer's brand. Creative designs and fast turnaround times, paired with the quality you've come to expect from Premier, turns a cruise through a wash into an illuminated adventure all can enjoy. Choose from our lineup of standard arches, or contact us for a one-of-a-kind custom design.

ADD PUCKS, SPINNERS OR DOTS FOR ADDED IMPACT!



ALL SIGNS ARE HAND CRAFTED AT OUR WISCONSIN FACILITY

Light Effects Arch with Shield Top Shown



5 Piece Grand Arch with Custom Shaped Top Shown

All of our signs are hand crafted with pride at our central Wisconsin facility. We offer a full line of standard arch shapes, or we can custom build an arch to suit your needs.

CHOOSE A STANDARD ARCH, OR MODIFY IT TO SUIT YOUR NEEDS





Badge Grand Arch with 4" Pucks and Dots Shown



Badge Arch



Badge Grand Arch Shown with Matching Sectional Menu

Shield Arch



Add Light Effect Options to Your Arch or Sign



4" LED Puck Lights

- Can be set to on, strobe or halo effect
- Available in green, blue, yellow, red and white



2" LED Spinners

- Available in green, blue, yellow, red, white and pink



1" Dot Light

- Available in white

Flashers and Sequence Flashers



Premier Arch

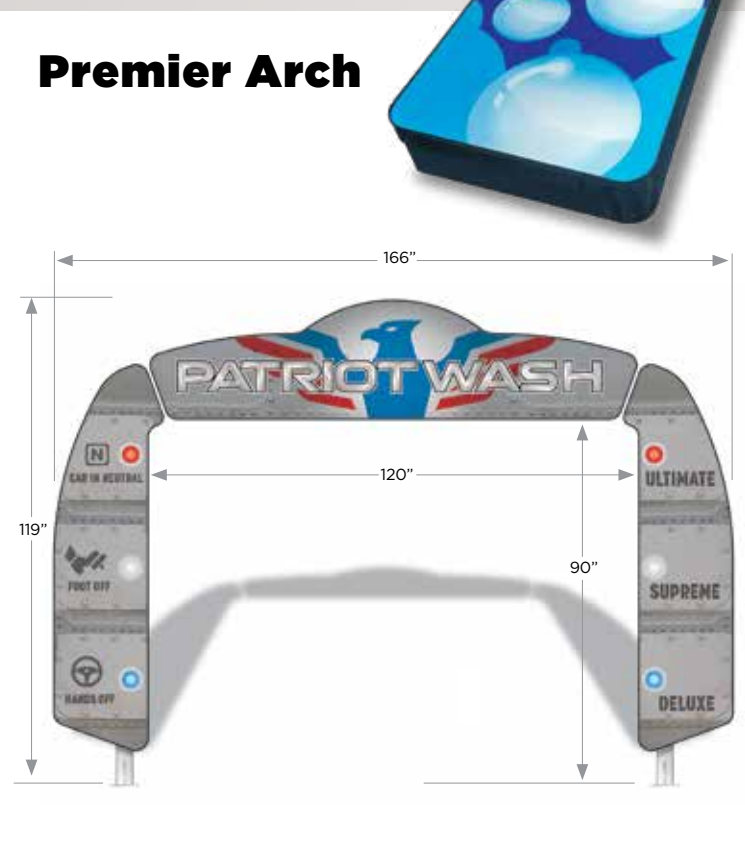

3 Piece Arch



5 Piece Arch



5 Piece Grand Arch Shown with Matching Sectional Menu

Rain Drop Arch

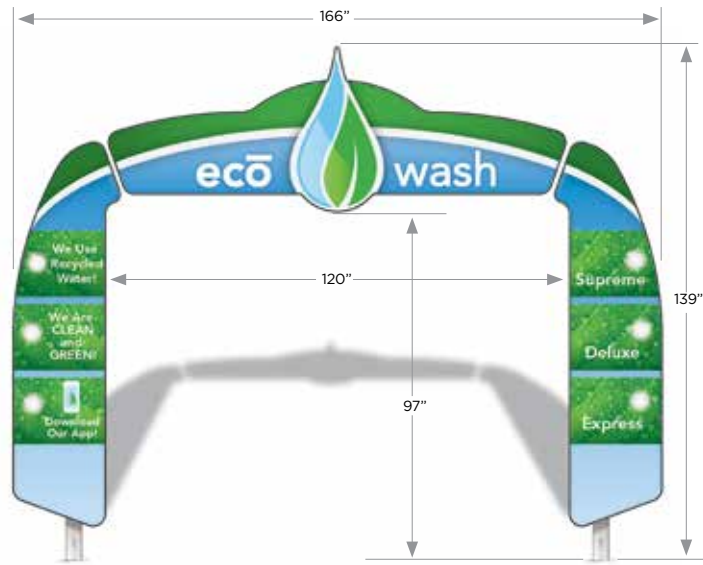

Light Effects Arch

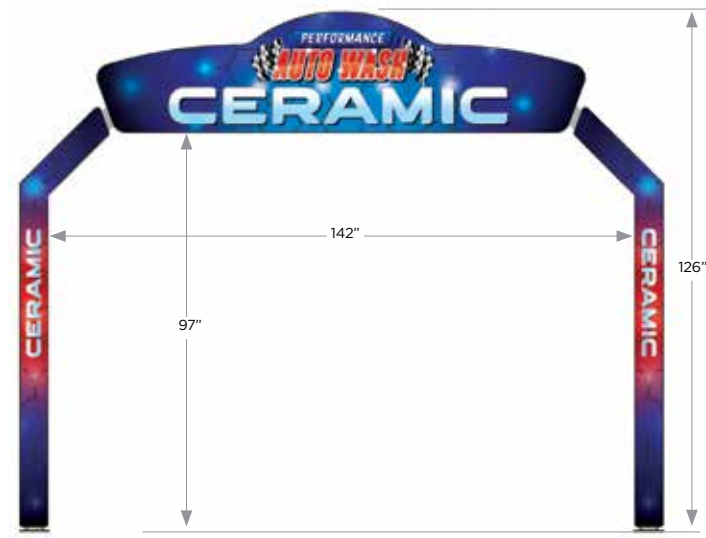

Custom Shaped Arches



Menu and Menu Boards



OUR DURABLE HDPE SECTIONAL MENU HOUSINGS ARE AVAILABLE IN 6 COLORS!

Sectional Menus

- 3-6 Sections Available
- 33" Wide x 96" High
- HDPE Color Options Include Red, Blue, Black, Granite Gray, Green and Yellow
- Custom Powder Coated Pedestal Available
- 120 Volt
- Aluminum Construction



Menu Boards

- Many Sizes Available
- Metal Color Options Include Red, Blue, Yellow, White and Black
- 120 Volt
- Aluminum Construction



Custom Menu Boards

- Create a Menu That Matches Your Image and Logo
- Metal Color Options Include Red, Blue, Yellow, White and Black
- 120 Volt
- Aluminum Construction



Instructionals & Sectionals

- Available in Single Post or Wall Mount
- 120 volt
- Dual Pivot Stainless Steel Arms for Adjustability
- Metal Color Options Include Red, Blue, Yellow, White and Black
- HDPE Color Options Include Red, Blue, Black, Granite Gray, Green and Yellow





Wall Mount & Pedestal Sectionals

- 2 - 8 sections available
- All signs are 120 Volt
- Dual pivot stainless steel arms for adjustability
- LED puck color options: red, white, blue, yellow and green
- Powder coat color options: red, blue, black, yellow and white
- Stainless steel construction
- HDPE housing colors:

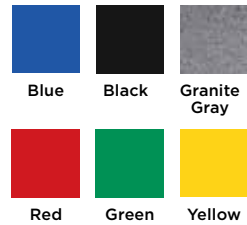

Tunnel/Wall Signs

- HDPE and aluminum housings available
- LED spinner light color options: red, blue, green, yellow, pink and white
- Stainless steel construction
- HDPE housing colors:

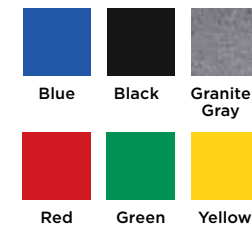

- 24" round or square



- 24" round with timer



OUR DURABLE HDPE HOUSINGS ARE AVAILABLE IN 6 COLORS!

12" X 47.5" SHOWN WITH 2" GREEN SPINNERS

Roto-Molded Signs

- All signs are 120 Volt
- Stainless steel construction
- HDPE housing colors:



CLEARANCE 7'6"

Clearance



ALL SHAPES AVAILABLE IN WALL MOUNT OR PEDESTAL

Channel Letters



Shown Unlit



Shown Lit with Color Chasing Arrow

- 24", 30" and 36" letters available
- Many options and colors available. Please call for more information.

Custom Shaped Pedestals & Wall Mounts



Because we build everything in-house, our experienced team of designers, engineers and craftsmen have the capability to build just about any shape of sign your customers might need. Let us know how we can help.

ACM Printed Signage

(Aluminum Composite Material)

- Laminated with a UV resistant material for added durability
- Can be used in-bay or outside
- Many sizes available
- Can be wall-mounted or mounted to a post



Styrene and Coroplast Signage

- Laminated with a UV resistant material for added durability
- Pump toppers
- WindMaster® inserts
- Many sizes and options available

ACM Printed In-Bay Signage

(Aluminum Composite Material)

- Laminated with a UV resistant material for added durability
- Can be used to add color to and promote products in self serve bays
- Many sizes available
- Can be wall-mounted



Pay Station Canopies



Double Leg Canopy

- Shown With Laser Cut "Pay Here" and Lit Roto-Molded "Clearance" Signs
- Roof Live Load: 40 psf
- RFID Reader Mount Available
- Single Leg Canopy Available (Flat Top Only)
- Basic Wind Speed: 130 mph



Arch Canopy Top

- Shown With LED Lit "Pay Here" and Lit Roto-Molded "Clearance" Signs
- Roof Live Load: 40 psf
- RFID Reader Mount Available
- Basic Wind Speed: 150 mph

Features

- Double coated powder coating process with a zinc primer base and colored second coat
- Powder coated extruded aluminum top without ridges to eliminate debris buildup and nesting
- Laser-cut holes in post for neat and efficient electrical installation
- RFID reader mount available
- Footing covers for a clean look

Lighting Options

- (1) 4' 5K LED included
- RGB upgrade available
- Jumper cables and off-site controls available with the Premier Hub

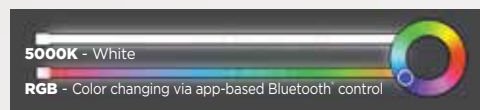

Included

- Laser-cut "Pay Here" sign
- (1) 4' 5K LED

Color Options

- Blue, black, red, green or yellow
- Custom colors available by request

Optional Upgrades

- Additional LED lighting
- J-anchor template kit
- Lit "Pay Here" sign
- Lit "Clearance" sign
- Customizable artwork to meet your customer's expectations and brand



LED Sign Lit Options



Unlit Sign Options



Clearance Structures & Signs

Straight Top Clearance Structures

- Built in-house
- Many powder coat colors available



MANY POWDER COAT COLORS ARE AVAILABLE!



Curved Top Clearance Structures

- Built in-house
- Many powder coat colors available
- Shown with custom ACM printed sign

Roto-Molded Clearance Signs

- Available both Lit and Unlit
- Custom designs and colors available
- HDPE housing colors:

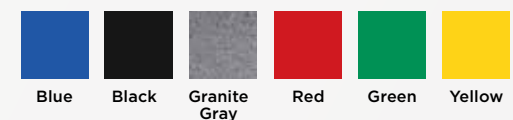

Dual Leg Clearance Structures

- Built in-house
- Many powder coat colors available
- Can be customized to any size needed



Stainless Steel Canopy Vacs

2 OR 3 MOTOR OPTIONS (220v motor upgrade available):

- 2 - 120v motors with 2" hose: FLA = 25 amps, 223 CFM, 910 AirWatts
- 3 - 120v motors with 2" hose: FLA = 35 amps, 315 CFM, 1212 AirWatts
- 220v motors:
 2 motors = 15 amps, 223 CFM, 620 AirWatts
 3 motors = 25 amps, 315 CFM, 931 AirWatts

Vacuum Specs

- 4-bag filter system
- 2 accessible back doors for easy clean out
- Tough upholstery tool with swivel cuff
- Added money box lock bar for security
- **Express 1** includes push button or toggle switch options
- **Express 2** offers multiple timer, coin, bill and credit card options
- Powder coating available
- Other options include light poles with LED lights, post covers and mat holders
- Dome colors:
- Hose colors:
- Canopy colors:
- Custom canopy colors available upon request

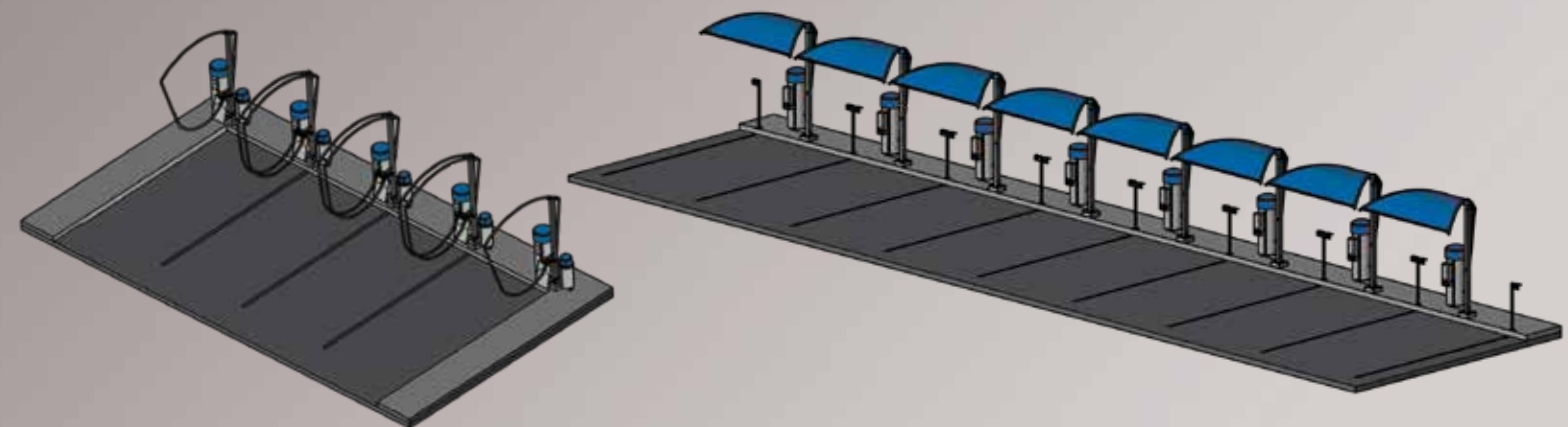

Premier Express-1 Vac

- Single vac station with boom
- LED upgrades available
- Push button or toggle switch start



Premier Single Express-2 Vac With Meter Box

- Single vac station with dual boom
- Canopy add-on for dual vac station
- Pedestal mounted nozzle holder
- LED upgrades available



Premier Single Express-2 Vac With Meter Box

- Single vac station with dual boom
- Canopy add-on for dual vac station
- Garbage can add-on
- LED upgrades available



Premier Express-1 Vac With Dual Straight Booms

- Designed for multiple stall use
- Shown with optional mat holder and trash can
- LED upgrades available



Stainless Steel Vacs

2 OR 3 MOTOR OPTIONS (220v motor upgrade available):

- 2 - 120v motors with 2" hose: FLA = 25 amps, 223 CFM, 910 AirWatts
- 3 - 120v motors with 2" hose: FLA = 35 amps, 315 CFM, 1212 AirWatts
- 220v motors:
 - 2 motors = 15 amps, 223 CFM, 620 AirWatts
 - 3 motors = 25 amps, 315 CFM, 931 AirWatts



Premier Express Vac

- 2 or 3 motor options (3 motor 35 FLA, 2 motor 25 FLA)
- 4-bag filter system
- 2 accessible back doors for easy clean out
- Tough upholstery tool with swivel cuff
- Added money box lock bar for security
- **Express 1** includes push button or toggle switch options
- **Express 2** offers multiple timer, coin, bill and credit card options
- **Express 3** features air and vacuum
(Not available with 3rd motor)



Premier Aroma Vac

- 2 or 3 120v motor options (3 motor 35 FLA, 2 motor 25 FLA)
- Dispenses 3 fragrances of your choice
- 4-bag filter system
- 2 accessible back doors for easy clean out
- Tough upholstery tool with swivel cuff
- Bright LED display timer with adjustable price per function
- Optional coin, bill or credit card acceptors

Silver Bullet

- Stainless steel cabinet
- Crevice tool
- Easy clean out door
- Single 120v motor
- Wire with another vacuum or toggle switch option

• Plastic domes available in:

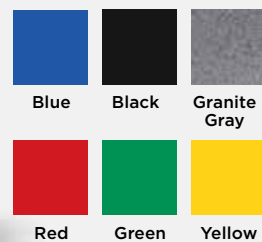

Premier Vacs are equipped with newly designed high efficiency vacuum motors gaining 85% more performance with two motors, outperforming the competition's three motor and central vac systems. Want even more performance? A third motor will not disappoint.

- Options include light poles with LED lights, post covers mat holders and daylight sensors
- Available hose colors: red, blue, yellow, black and gray
- Available standard and lit dome colors:

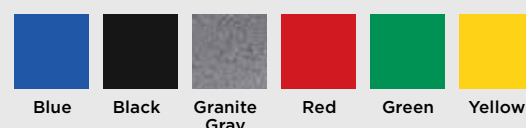

Premier Executive Vac

- 2 or 3 120v motor options (3 motor 35 FLA, 2 motor 25 FLA)
- 4-bag filter system
- Dispenses shampoo and 3 fragrances of your choice
- 2 accessible back doors for easy clean out
- Tough upholstery tool with swivel cuff
- Bright LED display timer with adjustable price per function
- Can be set up to accept coins, bills and/or credit cards



Premier Magic Vac

- 2 or 3 120v motor options (3 motor 35 FLA, 2 motor 25 FLA)
- Dispenses shampoo and spot remover
- 4-bag filter system
- 2 accessible back doors for easy clean out
- Tough upholstery tool with swivel cuff
- Bright LED display timer with adjustable price per function
- Multiple coin, bill and credit card acceptor options



MANY HOSE AND DOME COLOR OPTIONS AVAILABLE



Palm Dryers

- **110V AC**
(3 Motor) 50 amp service
(2 Motor) 30 amp service
- **240V AC**
(3 Motor) 25 amp service
(2 Motor) 20 amp service
- Relay: 110v, 24v or wired direct
- Available in attic mount, half wall pedestal mount or wall mount
- Available hose colors: red, blue, yellow, black and gray
- Available dome colors:



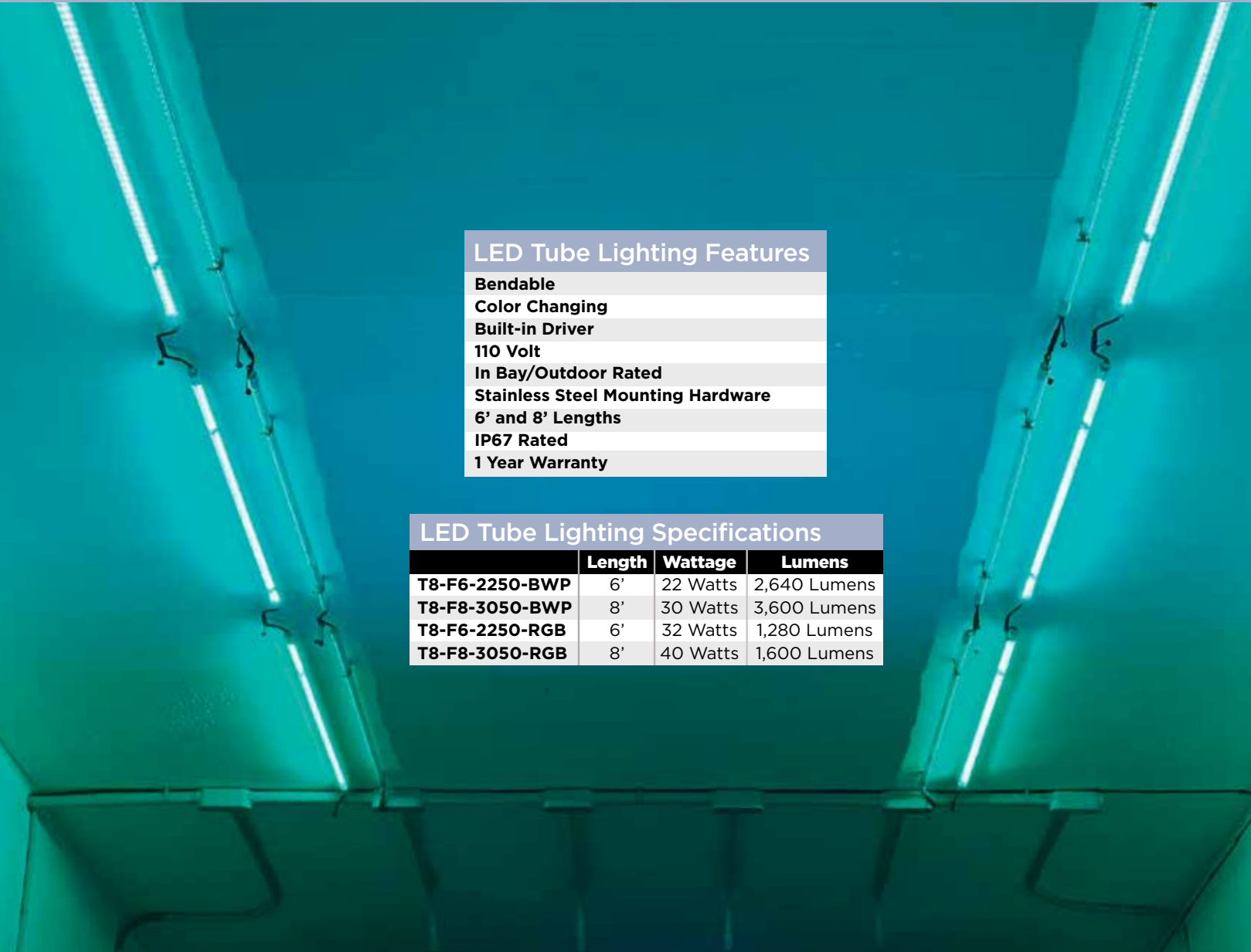

LED Tube Lighting Features

- Bendable
- Color Changing
- Built-in Driver
- 110 Volt
- In Bay/Outdoor Rated
- Stainless Steel Mounting Hardware
- 6' and 8' Lengths
- IP67 Rated
- 1 Year Warranty

LED Tube Lighting Specifications

	Length	Wattage	Lumens
T8-F6-2250-BWP	6'	22 Watts	2,640 Lumens
T8-F8-3050-BWP	8'	30 Watts	3,600 Lumens
T8-F6-2250-RGB	6'	32 Watts	1,280 Lumens
T8-F8-3050-RGB	8'	40 Watts	1,600 Lumens



COLOR CHANGING
POWERED BY THE
PREMIER APP!



The Premier LED App allows complete access to lighting controls from your phone, tablet or computer.

Control multiple locations and make changes while off-site with ease using the Premier Hub.

Premier Tube Lighting is bendable and made to be in bay, as well as outdoors. These lights create an eye-popping focal point for your facilities and outdoor canopy systems.

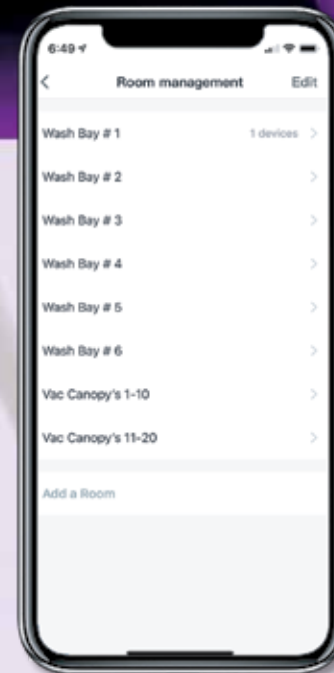

ROOM
MANAGEMENT
CONTROLLED BY
THE APP



VISIT US ONLINE



premier

Your Manufacturing Partner

2210 Heldt Street
Merrill, WI 54452
866.539.3100
sales@precisionlaser cutting.com
premiercompaniesusa.com

